

# MODEL : EOHM

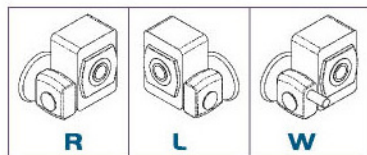
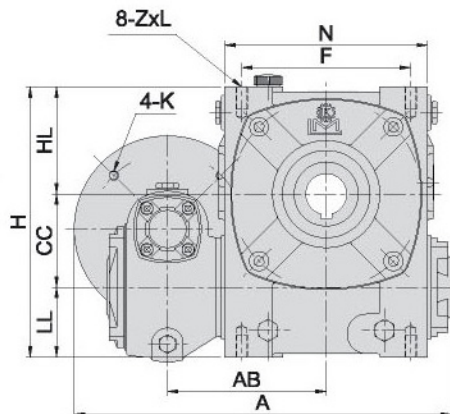
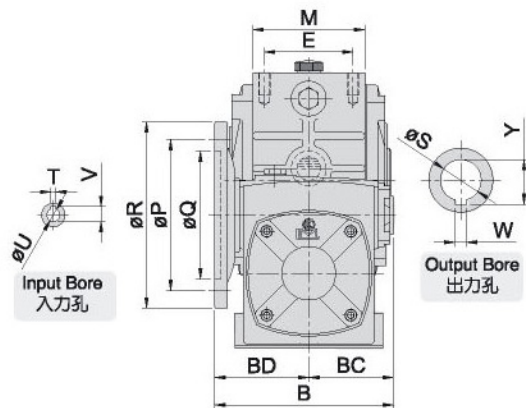

軸向選擇 Shaft Direction

## 尺寸表 Dimension(m/m)

減速比 RATIO	馬力 HP		A	AB	B	BD	BC	CC	LL	HL	H	馬達盤 IEC MOTOR FLANGE				腳座 FOOT STOCK				入力孔 INPUT BORE			出力孔 OUTPUT BORE			重量 Weight (KG)		
	型號 MODEL	1/100- 1/900										1/1000- 1/3600	P	Q	R	K	E	F	M	N	ZxL	V	T	U	W		Y	S
80	1/4		323	136	151	81	70	80	60	92	232	130	110	160	M8	75	145	98	175	M10x20	12.7	4	11	10	38.3	35	26	
100	1/2	1/4	370	158	176	86	90	100	75	115	290	130	110	160	M8	85	185	117	226	M12x24	12.7	4	11	10	43.3	40	45.6	
																					16.3	5	14					
120	1	1/2	424	185	202	102	100	120	95	155	370	130	110	160	M8 M10	100	220	132	264	M14x28	16.3	5	14	12	48.3	45	69.4	
			444									165	130	200							21.8	6	19					
135	2	1	499	219	226	116	110	135	105	185	425	165	130	200	M10	110	260	150	306	M16x35	21.8	6	19	15	59.3	55	92.4	
																					27.3	8	24					